



www.alls.ee





LineaV





LineaV

- # Contemporary minimal design with a sleek finish look.
- # Top and side mount fixation types or fencing.
- # Fast and easy assembly as well as installation.
- # 80% of fabrication is done in-house while only 20% needs to be finished on site.
- # Split section top handrail connects total span of railings.
- # Uniform length of flat bar profile for concrete fixation.
- # Choice of different vertical balustrades.
- # All components are made of durable aluminium.
- # Available in wide range of powder coating finishes.



Railings



Top

mount



- # Top mount fixation balustrades with the use of concrete screws.
- # Load resistance category UDL 1KN/m.
- # Maximum balustrade height 1.2 m from the concrete floor level.
- # Fixation onto flat bar profile of uniform length.
- # Easy installation due to absence of columns.
- # Minimal design.

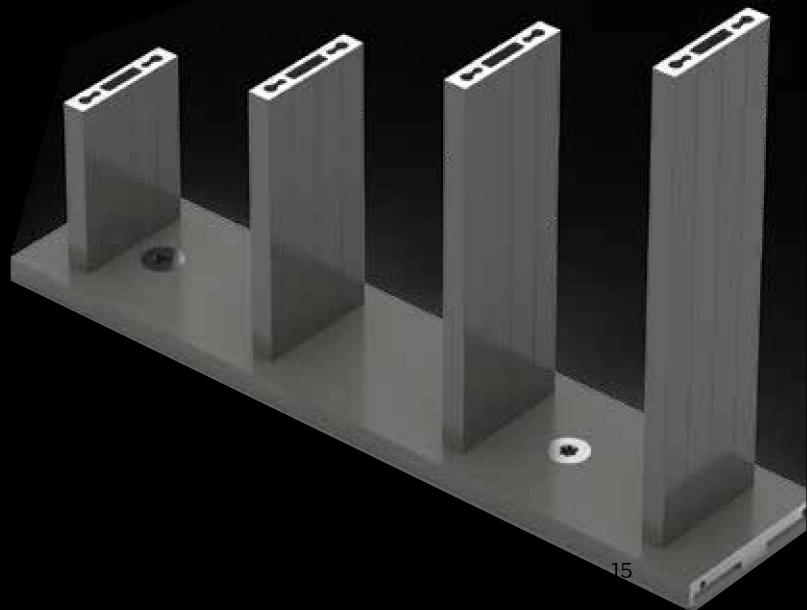

1

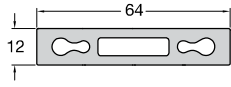

Code

FSN-100

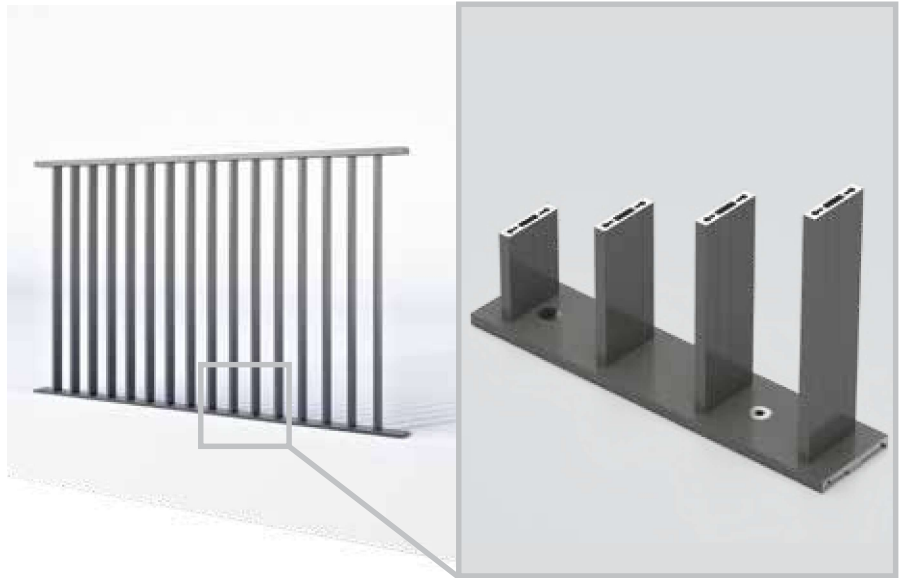

2

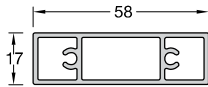

Code

FSN-302

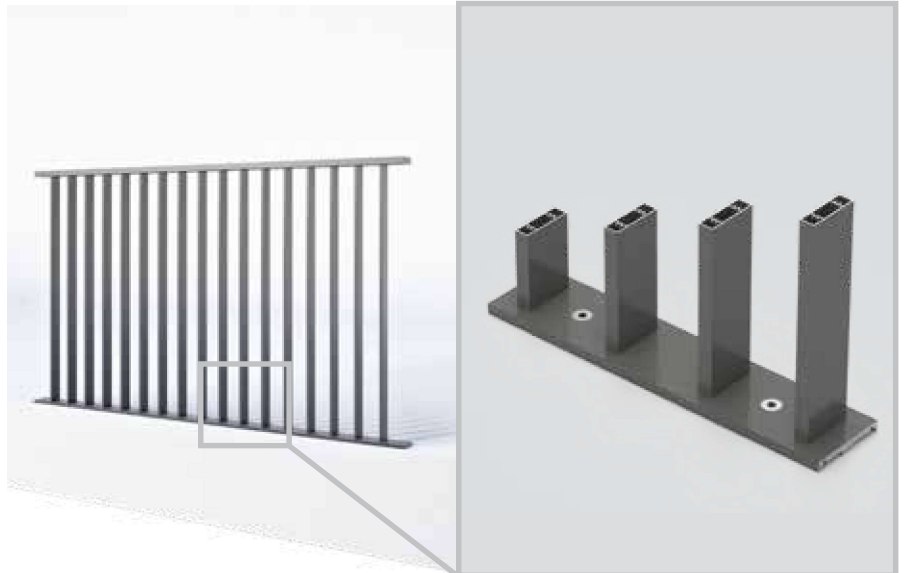

3

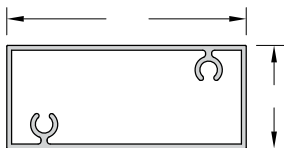

Code

FSN-401

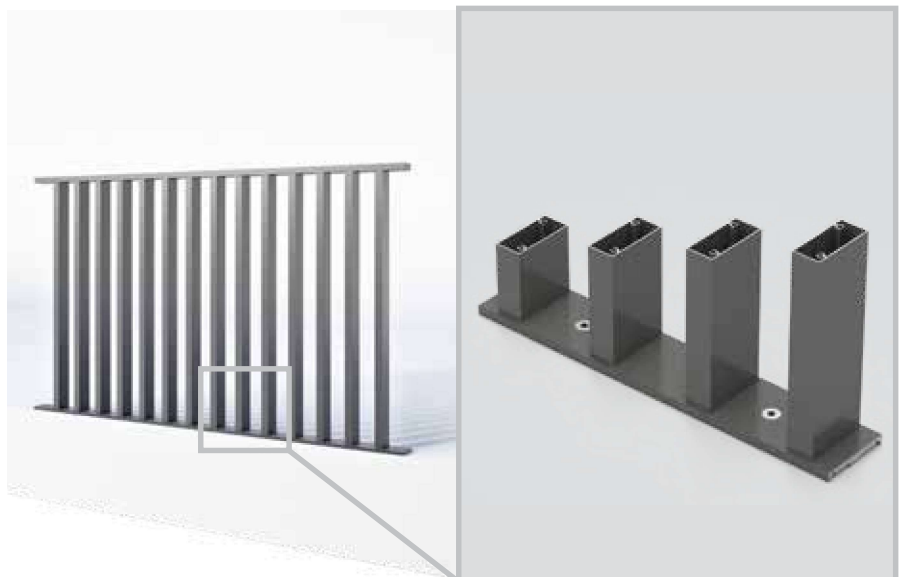

4

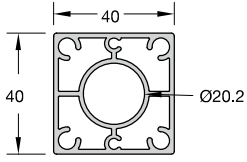

Code

CLS-102

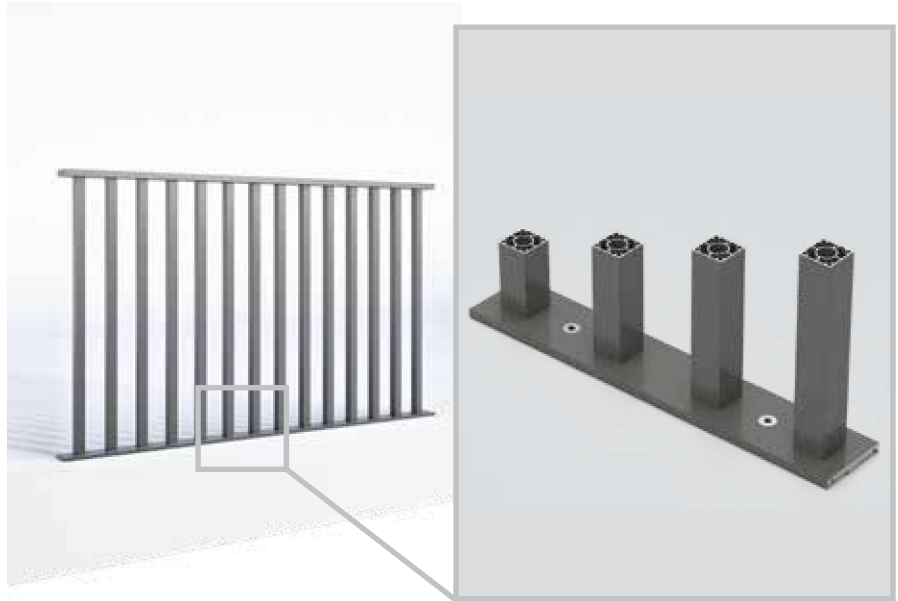

5

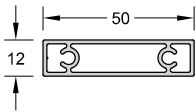

Code

FSN-106

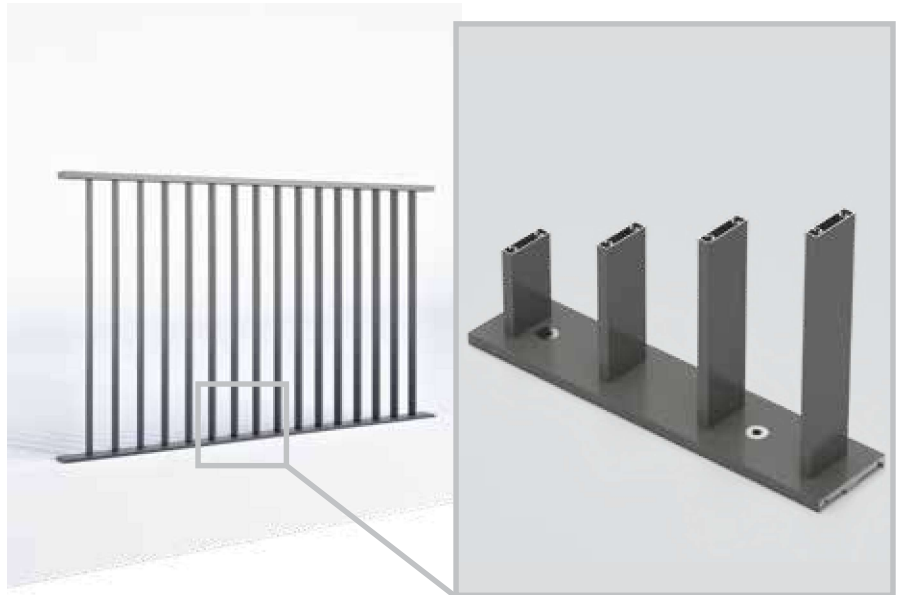

Top mount Assembly

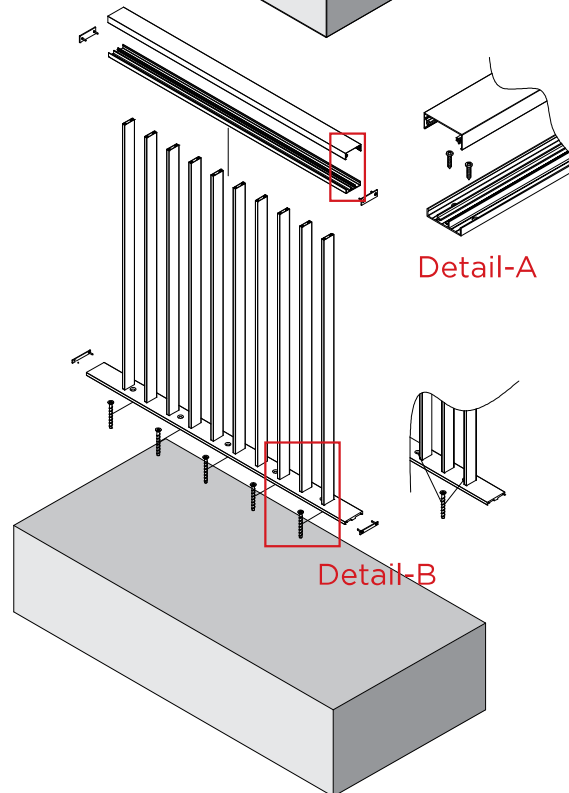
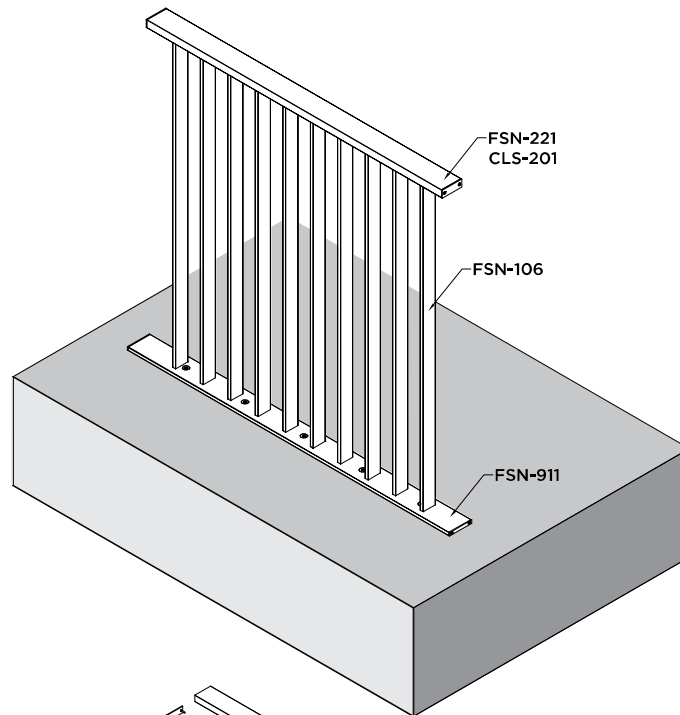

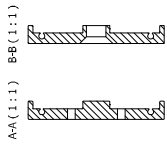
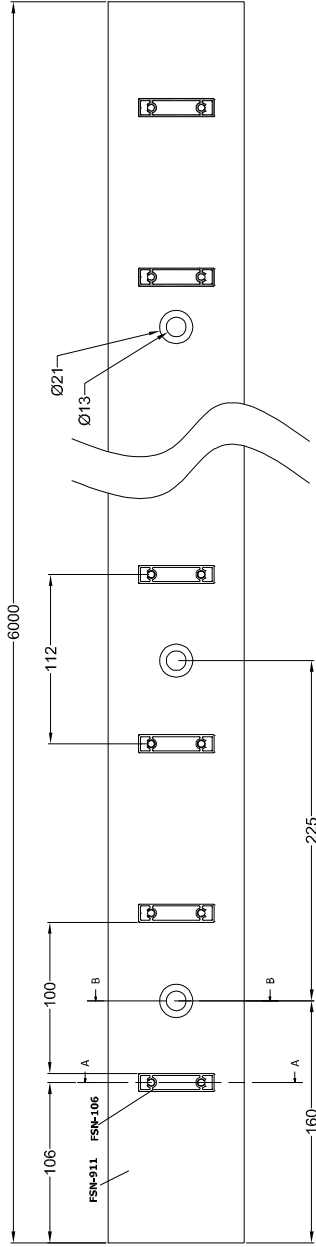
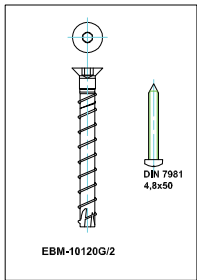



W
A
W

Side

mount



- # Side mount fixation balustrades with the use of concrete screws.
- # Load resistance category UDL 1KN/m.
- # Maximum balustrade height 1.2 m from the concrete floor level.
- # Fixation onto side mount profile of uniform length.
- # Easy installation due to absence of columns.
- # Minimal design.

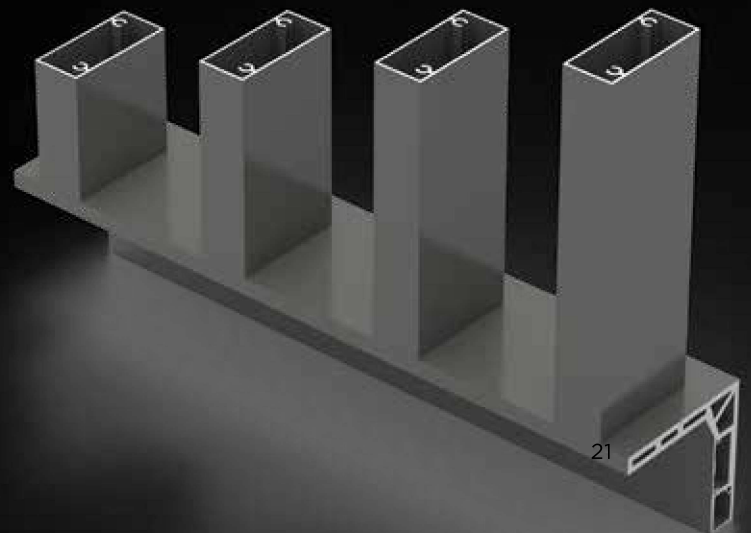

1

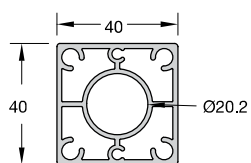

Code

CLS-102



2

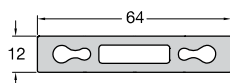

Code

FSN-100



3

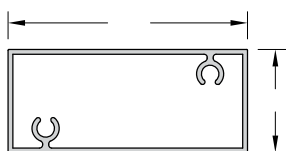

Code

FSN-401



4

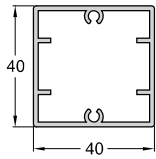

Code

F50-106



5

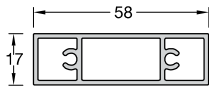

Code

FSN-302



6

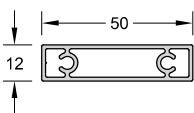

Code

FSN-106



Side mount Assembly

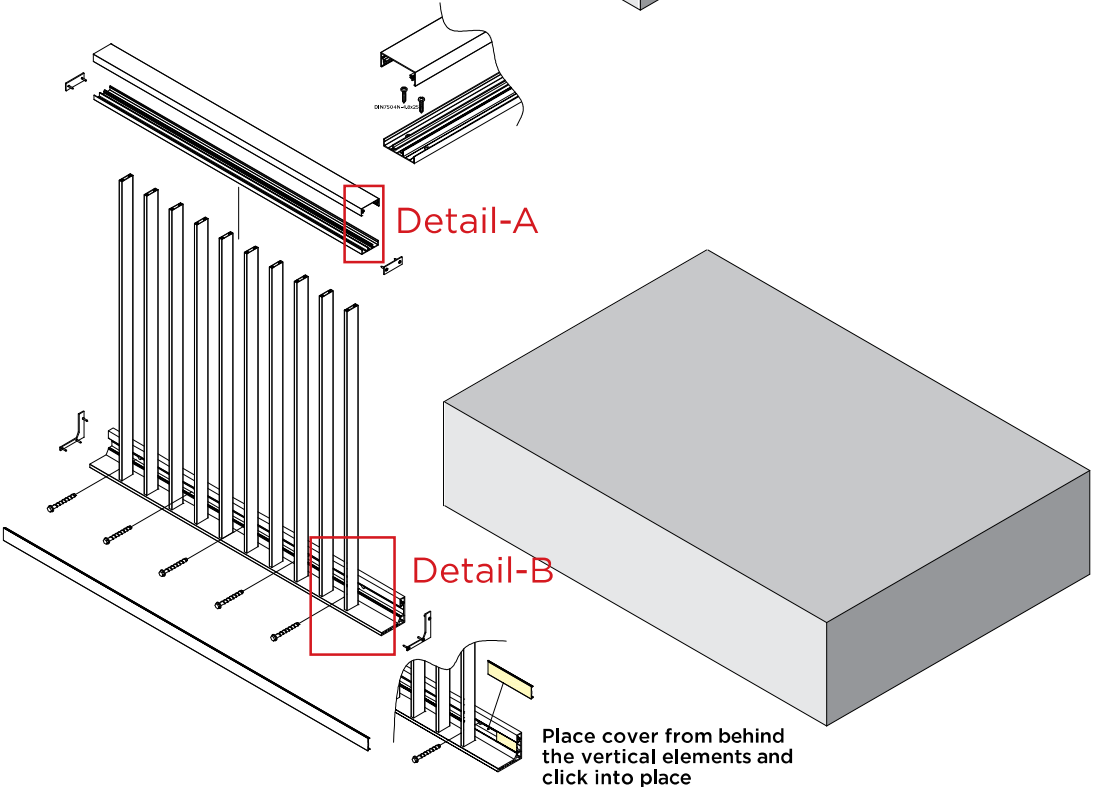
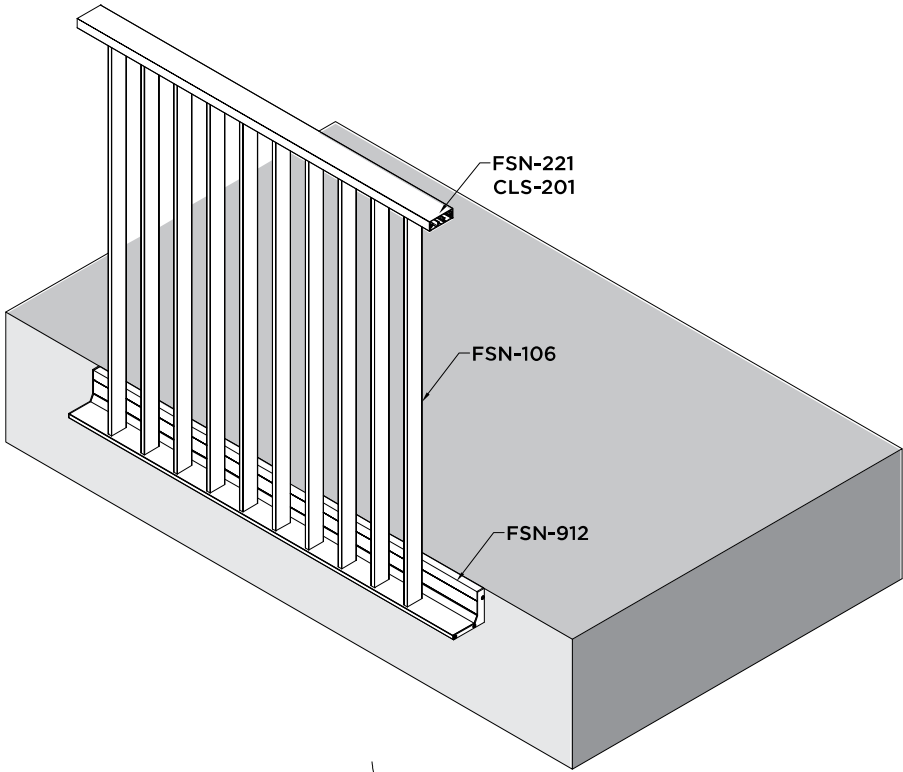

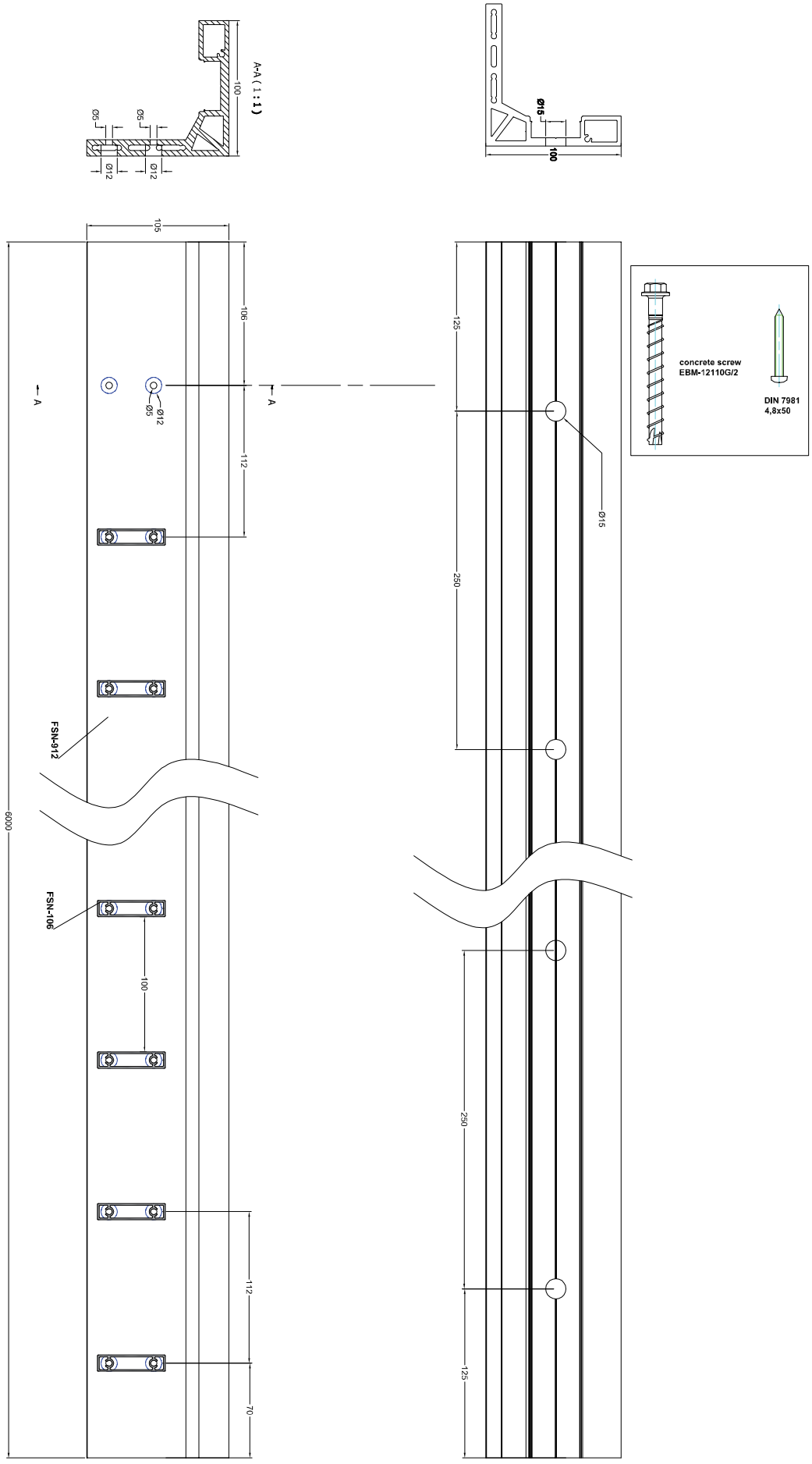

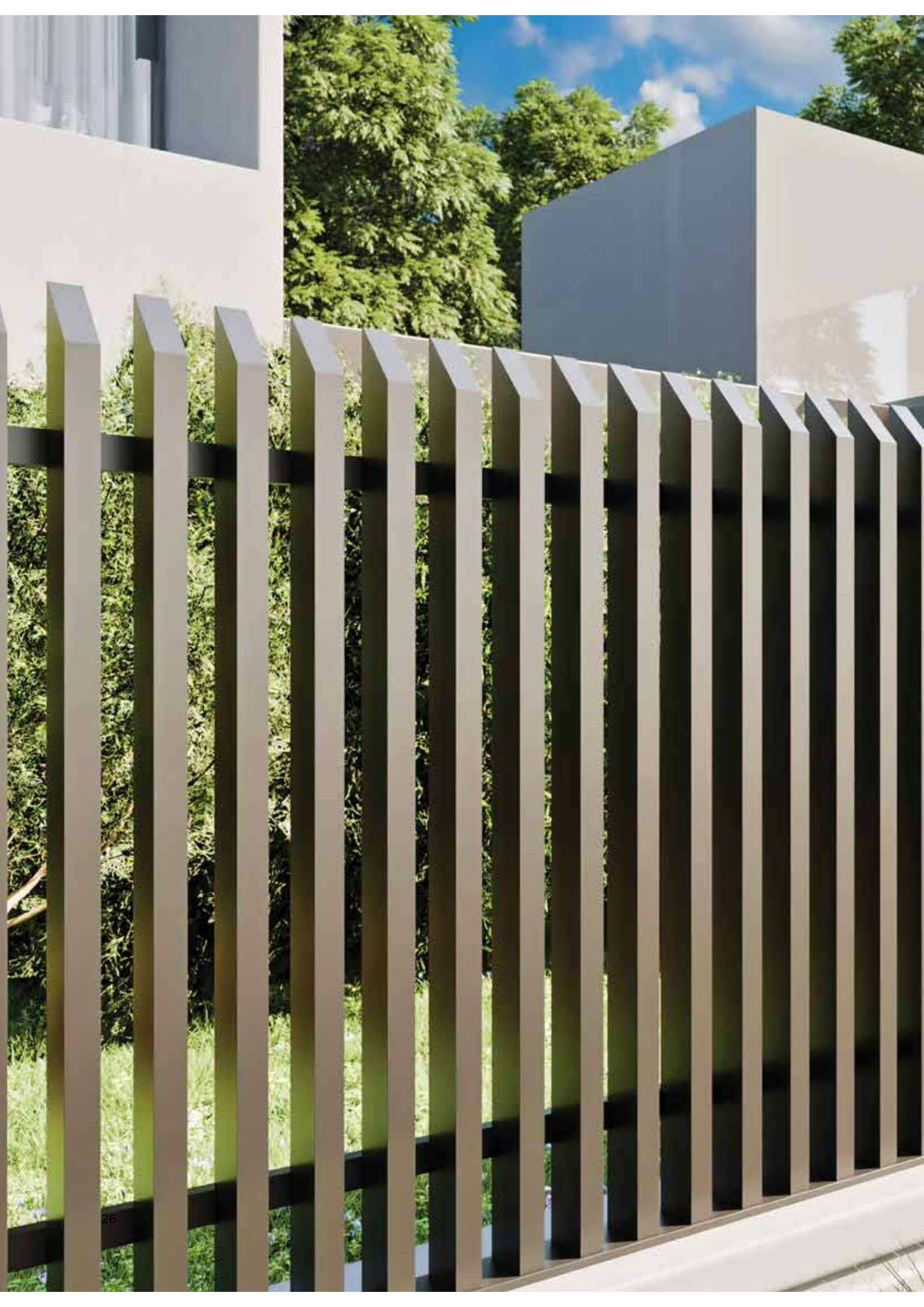

Fences



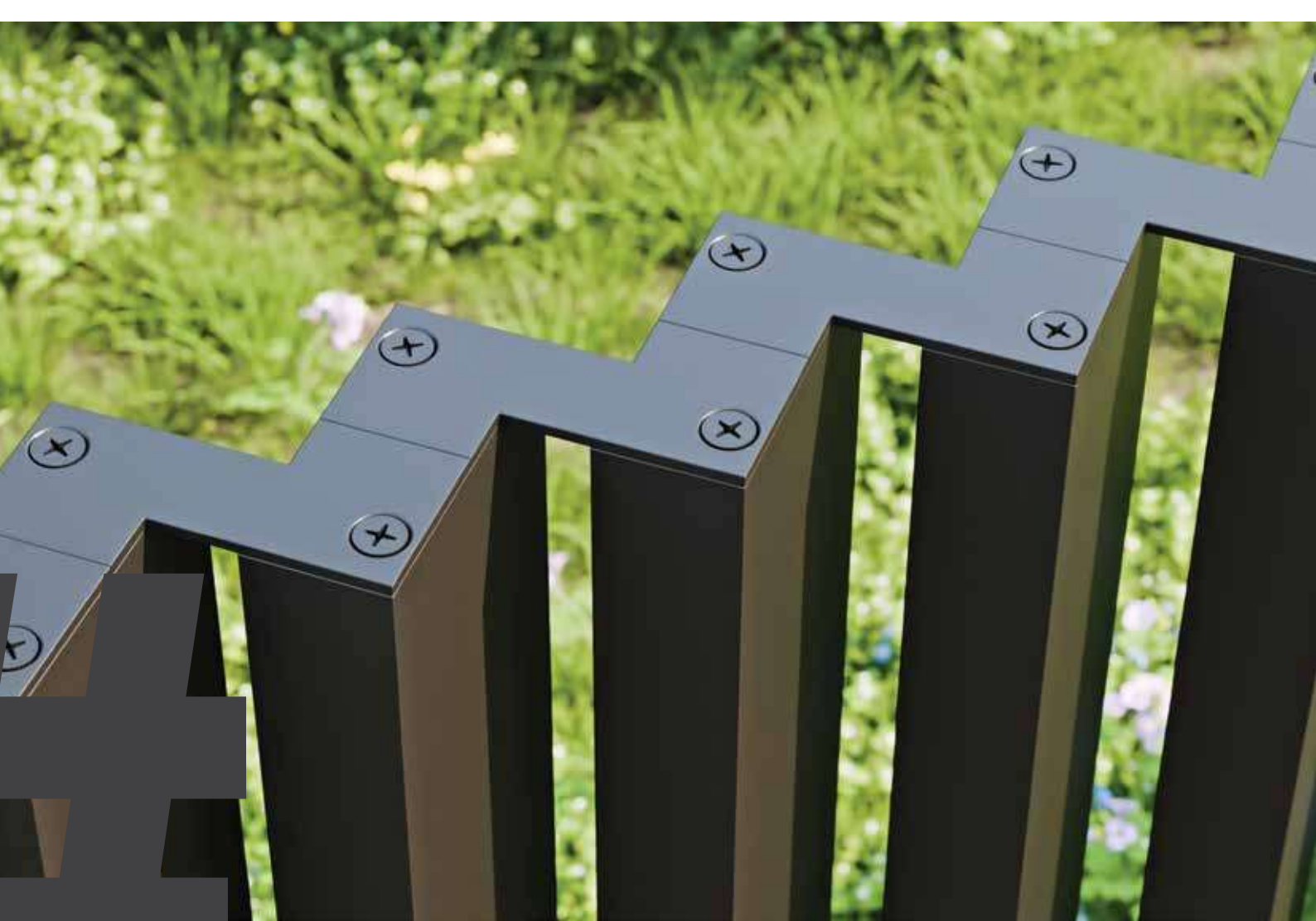

Fences





- # Top mount fixation fence with the use of concrete screws.
- # Column load resistance 1KN.
- # Maximum balustrade height 1.3 m from the concrete floor level.
- # Fixation onto flat bar profile of uniform length.
- # Angular placed columns, use of top covers instead of handrail.
- # Easy installation, minimal design.

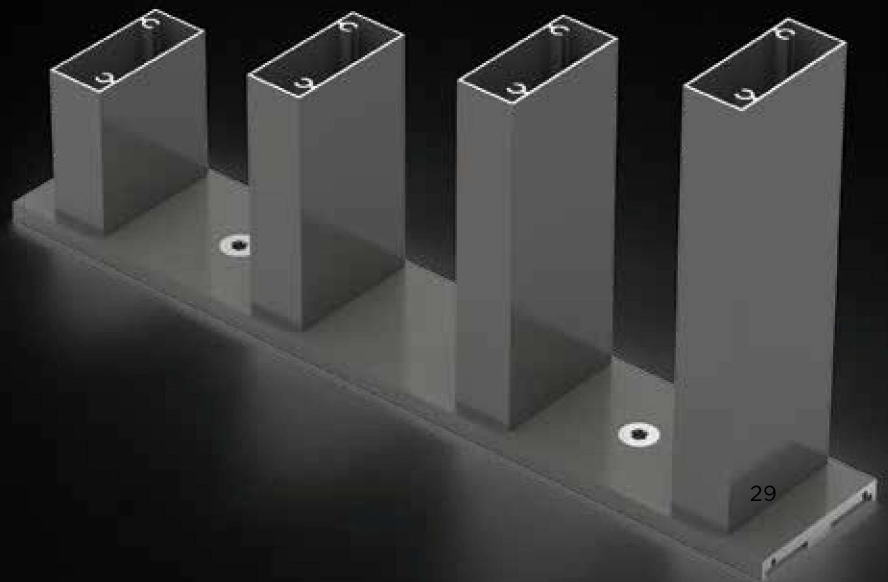

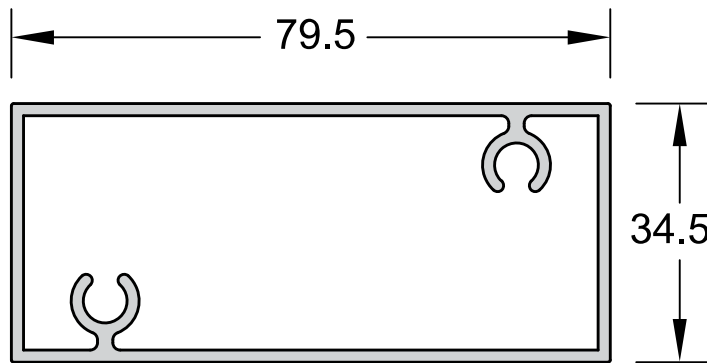

Code

FSN-401

L

1



2



3

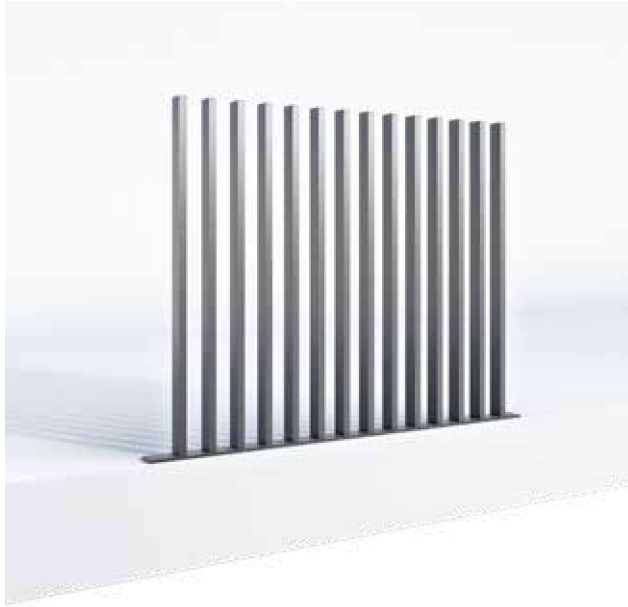

4

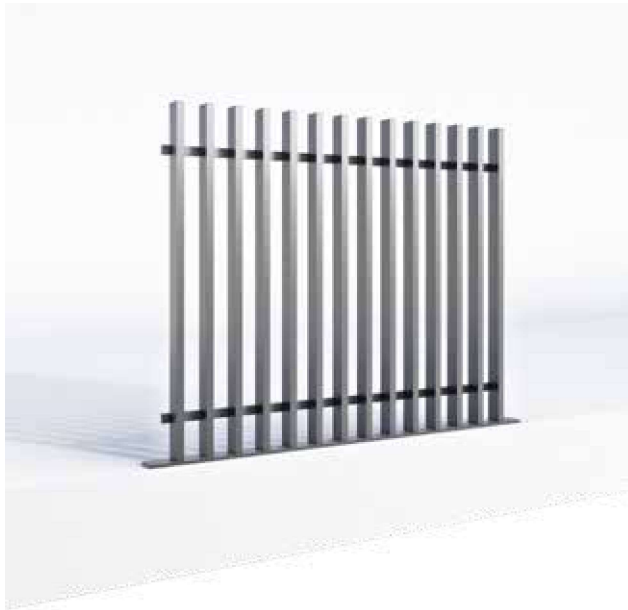

5



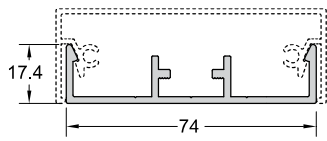

Code: **CLS-201**

BASE FOR HANDRAIL FSN-221/222

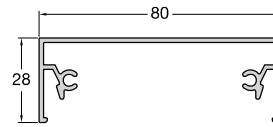

Code: **FSN-221**

COVER FOR HANDRAIL 80x28

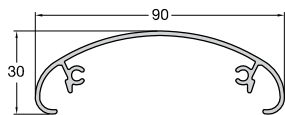

Code: **FSN-222**

COVER FOR HANDRAIL OVAL 90x30

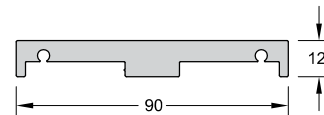

Code: **FSN-911**

COVER FOR HANDRAIL OVAL 90x30

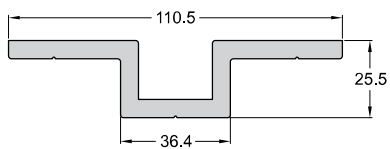

Code: **P5302-902**

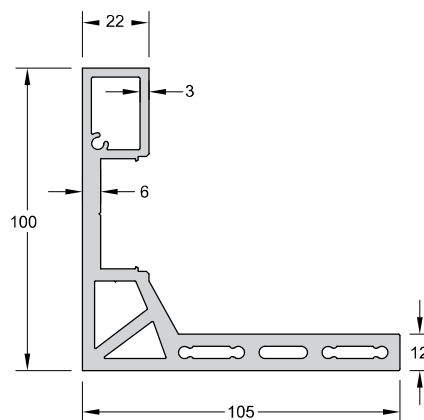

Code: **FSN-912**

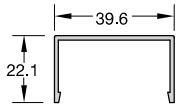

Code: **CLS-3K2**

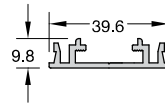

Code: **CLS-302**

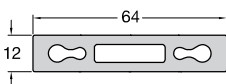

Code: **FSN-100**

COLUMN 12x64

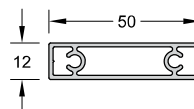

Code: **FSN-106**

LENGTH: 6m

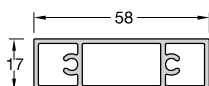

Code: **FSN-302**

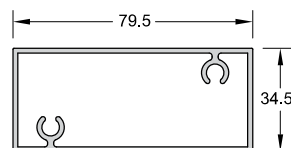

Code: **FSN-401**

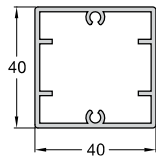

Code: **F50-106**

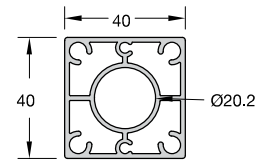

Code: **CLS-102**

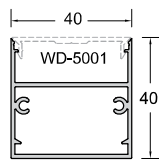

Code: **WD-4040**



Code: **4289**
CORNER CONNECTOR 90° FOR HANDRAIL CLS-201



Code: **4275**
CONNECTOR FOR GUIDE CLS-302



Code: **4270**
CONNECTOR FOR CLS-201/301/302/305



Code: **4922**
END CAP FOR HANDRAIL FSN-221



Code: **4921**
END CAP FOR HANDRAIL FSN-222



Code: **A334-006**
COVER FOR WD-4040



Code: **E4949**
SIDE COVER FOR FSN-911



Code: **E4950**
SIDE COVER FOR FSN-912 (PAA)



Code: **E4954**
SLOPE COVER 45° FOR FSN-401



Code: **E4953**

LINEAR COVER FOR FSN-401



Code: **E4952**

ANGULAR COVERS FOR FSN-401 / SUN LIGHT 20 mm /
RIGHT ALIGNMENT



Code: **E4952-B**

ANGULAR COVERS FOR FSN-401 / SUN LIGHT 20 mm /
LEFT ALIGNMENT



Code: **E4958**

ANGULAR COVERS FOR FSN-401 / SUN LIGHT 30 mm /
RIGHT ALIGNMENT



Code: **E4958-B**

ANGULAR COVERS FOR FSN-401 / SUN LIGHT 30 mm /
LEFT ALIGNMENT

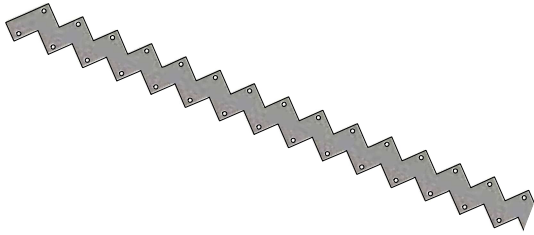

Code: **E4959**
SHEET METAL ANGLE 45° COVER FOR FSN-401 /
SUN LIGHT 20 mm / RIGHT ALIGNMENT

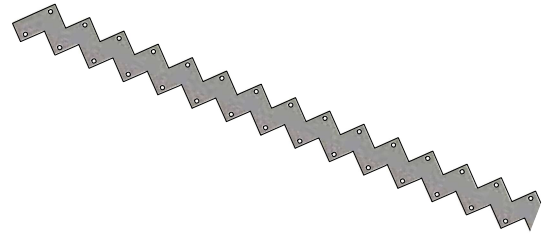

Code: **E4959-B**
SHEET METAL ANGLE 45° COVER FOR FSN-401 /
SUN LIGHT 20 mm / LEFT ALIGNMENT

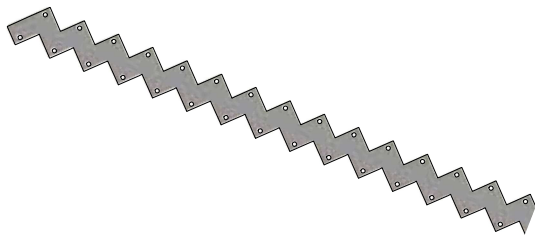

Code: **E4960**
SHEET METAL ANGLE 45° COVER FOR FSN-401 /
SUN LIGHT 30 mm / RIGHT ALIGNMENT

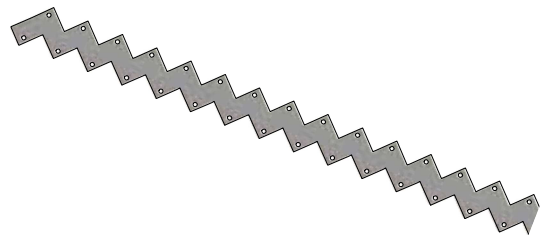

Code: **E4960-B**
SHEET METAL ANGLE 45° COVER FOR FSN-401 / SUN LIGHT
30 mm / LEFT ALIGNMENT